

PRODUCT DATA

9 09 67 23 **Resinous  
Flooring**

# UCRETE® HF

## Polyurethane-concrete resurfacing system

### Description

Ucrete® HF is a three-component polyurethane-concrete flooring system. This troweled, monolithic flooring system is installed from 1/4 – 3/8" (6 – 9.5 mm) or greater. The thickness is determined by the service and cleaning temperatures and the severity of traffic expected.

Ucrete® HF floors are extremely tough and have many physical properties that exceed those of typical concrete.

### Yield

For coverage rates, refer to the Ucrete® Contractor Installation Guideline.

### Packaging

Parts 1 and 2: 1/2 gallon (1.9 L) cans, filled to provide the proper mixing ratio

Part 3: 43 lb (19.5 kg) bags

Part 4: 1 lb (0.4 kg) pigment packs

### Color

Red, gray, cream, green, and charcoal. Because Ucrete® HF is a colored polyurethane concrete, color uniformity cannot be completely guaranteed from batch to batch. Do not mix batches within a single area.

### Shelf Life

Part 1:

6 months when properly stored

Parts 2 and 3:

1 year when properly stored

Part 4:

2 years when properly stored

### Features

- Thermal stability
- Fast curing
- Solvent free
- No priming or sealing of substrate
- 30 years of project references
- Can be applied to 7 – 10 day old properly prepared concrete
- Extremely high bond strength
- Chemical resistant
- Unaffected by freeze/thaw cycles
- Wide temperature in-service range from -50 – 235° F (-45 – 112° C)
- Excellent impact and abrasion resistance
- Coefficient of thermal expansion similar to concrete
- Slip resistant

### Benefits

- Resists steam or continuous hot-water cleaning
- Minimizes down time
- Low odor; VOC compliant
- Single-lift application
- Proven track record
- Accelerates work schedules
- Reduces shear at bond line
- Tolerates organic and inorganic acids, alkalis and salts
- Handles wide temperature fluctuations
- Exceeds that of typical epoxy overlays
- Handles heavy traffic
- Prevents shear at bond line
- Meets ADA recommendations

### Storage

Store and transport in unopened containers in a clean, dry area in stable temperatures approximating 60 to 73° F (15 to 23° C).

### Where to Use

#### APPLICATION

- Where severe conditions exist—high impact pressure, thermal shock, and chemical exposure
- Where steam or hot water is required for cleaning
- Badly damaged surfaces that need a fast, economical resurfacer
- New construction projects
- Meat, poultry, and dairy plants,

- Bottling facilities
- Pharmaceutical plants
- Commercial kitchens and restaurants
- Pulp and paper mills
- Chemical processing facilities
- Waste-water treatment facilities
- Freezers and coolers

#### LOCATION

- Interior or exterior applications

#### SUBSTRATE

- New and existing concrete surfaces and toppings; when applying over other surfaces, contact BASF Technical Service

## Technical Data

### Composition

Ucrete® HF is a three-component polyurethane concrete.

### Compliances

- USDA accepted for use in federally inspected meat and poultry plants in the USA
- Ministry of Agriculture, Canada, accepted for use in food establishments in Canada
- British Standard Specifications (BSS), for use in the U.K.
- Meets ADA recommendations for a slip-resistant flooring surface

### Test Data

PROPERTY	RESULTS	TEST METHODS
<b>Compressive strength</b> , psi (MPa)	7,300 (50.3)	ASTM C 579
<b>Tensile strength</b> , psi (MPa)	800 (5.5)	ASTM C 307
<b>Coefficient of thermal expansion</b> , in/in/° F (cm/cm/° C)	1.1 x 10 <sup>-5</sup> (2.0 x 10 <sup>-5</sup> )	ASTM C 531
<b>Density</b> , lb/ft <sup>3</sup> (g/cm <sup>3</sup> )	130 (2.08)	ASTM C 905
<b>Resistance to fungi growth</b>	Passes, rating of one	ASTM G 21
<b>Impact resistance</b>	No visible damage or deterioration at minimum 160 in-lb	ASTM D 2794
<b>Compressive modulus</b> , psi (MPa)	1.7 x 10 <sup>5</sup> (1,170)	ASTM C 469
<b>Flexural strength</b> , psi (MPa)	1,800 (12.4)	ASTM C 580
<b>Modulus of elasticity</b> , psi (MPa)	1.7 x 10 <sup>5</sup> (1,170)	ASTM C 469
<b>Thermal conductivity</b> , BTU-in/in-ft <sup>2</sup> °F (W/mK)	8 (1.2)	ASTM C 177
<b>Water absorption</b> , %	< 0.1	ASTM C 413
<b>Abrasion resistance</b> , g loss; CS-17 Wheel, 1,000 cycles	0.07	ASTM D 4060
<b>Resistance to elevated temperatures</b>	No flow or softening	MIL-D-3134
<b>Adhesion</b> , psi (MPa)	400 (2.8) 100% concrete failure	ASTM D 4541
<b>Coefficient of friction</b> , wet and dry	Passes ADA recommendations	ASTM D 2047

### Chemical Resistance

In accordance with ASTM D 1308, Ucrete® HF will resist exposure for up to 48 hours at 72° F (22° C) for the following chemicals.

- Dilute mineral acids including hydrochloric (< 35%), phosphoric (< 50%), and sulfuric (< 30%)
- Alkalis, including potassium hydroxide to a 50% concentration
- Some dilute organic acids such as acetic (30%) formic, citric, and uric
- Fats, oils, and sugars
- Mineral oils, diesel fuel, kerosene, and gasoline
- Most organic solvents, including aliphatic and aromatic hydrocarbons and alcohol

NOTE: Full chemical resistance is achieved after curing for 7 days. For chemical resistance to a specific compound, consult the Chemical Resistance Guide. Contact your local BASF representative for more information.

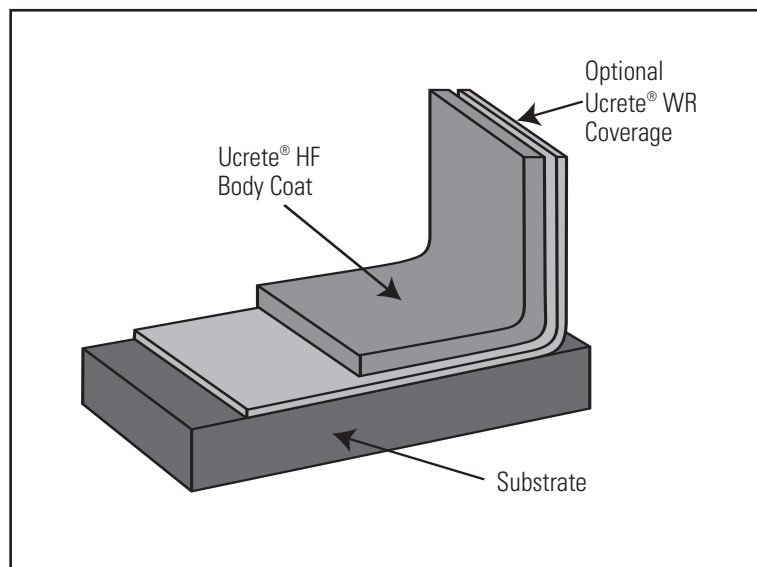

## How to Apply

Ucrete® systems are installed by approved contracting firms that have completed the manufacturer's training workshops. Ucrete® is a globally branded product line with industry synergies around the world.

The following is only a summary of the installation techniques used by your Ucrete® approved contractors. Refer to the Ucrete® Contractor Installation Guideline for more information.

### Surface Preparation

1. Floors must be structurally sound and properly cured. Test floor for vapor drive in accordance with ASTM D 4263.
2. Repair concrete as necessary.
3. Use a commercial degreaser to clean floors of oil, grease, and other bond-inhibiting materials.
4. Remove curing and parting compounds and other surface hardeners and floor coatings in accordance with the manufacturer's instructions.
5. Mechanical surface profiling is the method of surface penetration for both new and existing floors. Mechanically profile the floor to a minimum CSP 4-5 as described by the International Concrete Repair Institute.
6. Apply a 10 by 10 ft (3 by 3 m) test in an inconspicuous area that meets the owner's expectations for appearance, slip resistance, and performance.

### Application

1. Install Ucrete® WR cove base, as required. Refer to the Ucrete® Contractor Installation Guideline for details.

2. Mix the 3 components of Ucrete® HF using a mechanical mixer. The materials are supplied in pre-measured containers.

3. Screed or trowel apply the mixed material onto the floor. Hand trowel or power trowel the material to compact and level the topping to the specified thickness. Install to a thickness of 1/4 – 3/8" (6 – 9.5 mm), depending on the job requirements.

### Curing Time

The floor can be returned to full service after 12 – 24 hours at 70° F (21° C).

### Maintenance

Regular cleaning and maintenance will prolong the life of all polymer flooring systems, enhance their appearance, and reduce any tendency to retain dirt. Ucrete® HF will withstand steam-cleaning, high-pressure hot-water washdowns (2,500 psi [17.2 MPa] at 220° F [104° C]) along with a wide range of decontamination and degreasing materials.

### For Best Performance

- The owner and architect should discuss joint details with the flooring contractor before the job starts.
- Do not expose the Ucrete® HF to any chemicals until fully cured (12 – 24 hours at 70° F [21° C]).
- In climates with temperatures below 50° F (10° C), curing time could exceed 48 hours to reach full operational strength.
- Substrates on or below grade require an effective moisture-vapor barrier; if not present, please consult your BASF representative for options.

- The substrate must be structurally sound, clean, dry, and free of any foreign matter that could inhibit adhesion.
- Do not apply Ucrete® HF at temperatures below 40° F (4° C) or above 85° F (29° C) or if relative humidity is above 85%.
- Do not apply Ucrete® HF directly to unreinforced sand-cement screeds, asphalt, bitumen substrates, glazed tile or nonporous brick and tile, magnesite, copper, aluminum, existing coatings, epoxies, or polyesters. For optimal performance, apply directly to concrete. Consult with your BASF representative for further advice.
- Ucrete® HF is designed primarily as a one-step application product. Variation in the thickness will affect the system's thermal and impact resistance. Thicknesses from 1/4 – 1" (6 – 12 mm) are recommended, with the thicker systems providing the highest level of thermal shock and impact resistance.
- The final color of Ucrete® HF on both interior and exterior applications may shift under UV light exposure. The performance of the product, however, will not be affected.
- Build coves and vertical surfaces with Ucrete® WR. Contact BASF Technical Service for details.
- BASF representatives and flooring specialists are available to assist you in the selection of the proper flooring system. Call 1-800-243-6739 for in-house and field technical assistance.
- Make certain the most current versions of product data sheet and MSDS are being used; call Customer Service (1-800-433-9517) to verify the most current versions.
- Proper application is the responsibility of the user. Field visits by BASF personnel are for the purpose of making technical recommendations only and not for supervising or providing quality control on the jobsite.

### Health, Safety and Environmental

Read, understand and follow Material Safety Data Sheets and product labels for all components of this flooring system prior to use. The MSDS can be obtained by searching for them on [www.BuildingSystems.BASF.com](http://www.BuildingSystems.BASF.com), e-mailing your request to [basfscst@basf.com](mailto:basfscst@basf.com) or calling 800/433-9517. Use only as directed.

**BASF Construction Chemicals, LLC –  
Building Systems**

889 Valley Park Drive  
Shakopee, MN, 55379

[www.BuildingSystems.BASF.com](http://www.BuildingSystems.BASF.com)

**Customer Service** 800-433-9517  
**Technical Service** 800-243-6739



**LIMITED WARRANTY NOTICE** Every reasonable effort is made to apply BASF exacting standards both in the manufacture of our products and in the information which we issue concerning these products and their use. We warrant our products to be of good quality and will replace or, at our election, refund the purchase price of any products proved defective. Satisfactory results depend not only upon quality products, but also upon many factors beyond our control. Therefore, except for such replacement or refund, **BASF MAKES NO WARRANTY OR GUARANTEE, EXPRESS OR IMPLIED, INCLUDING WARRANTIES OF FITNESS FOR A PARTICULAR PURPOSE OR MERCHANTABILITY, RESPECTING ITS PRODUCTS,** and BASF shall have no other liability with respect thereto. Any claim regarding product defect must be received in writing within one (1) year from the date of shipment. No claim will be considered without such written notice or after the specified time interval. User shall determine the suitability of the products for the intended use and assume all risks and liability in connection therewith. Any authorized change in the printed recommendations concerning the use of our products must bear the signature of the BASF Technical Manager.

This information and all further technical advice are based on BASF's present knowledge and experience. However, BASF assumes no liability for providing such information and advice including the extent to which such information and advice may relate to existing third party intellectual property rights, especially patent rights. In particular, BASF disclaims all **CONDITIONS AND WARRANTIES, WHETHER EXPRESS OR IMPLIED, INCLUDING THE IMPLIED WARRANTIES OF FITNESS FOR A PARTICULAR PURPOSE OR MERCHANTABILITY, BASF SHALL NOT BE RESPONSIBLE FOR CONSEQUENTIAL, INDIRECT OR INCIDENTAL DAMAGES (INCLUDING LOSS OF PROFITS) OF ANY KIND.** BASF reserves the right to make any changes according to technological progress or further developments. It is the customer's responsibility and obligation to carefully inspect and test any incoming goods. Performance of the product(s) described herein should be verified by testing and carried out only by qualified experts. It is the sole responsibility of the customer to carry out and arrange for any such testing. Reference to trade names used by other companies is neither a recommendation, nor an endorsement of any product and does not imply that similar products could not be used.

**For professional use only. Not for sale to or use by the general public.**

Form No. 1025793 9/07

Printed on recycled paper including 10% post-consumer fiber.

© 2007 BASF  
Printed in U.S.A.