

PRODUCT DATA

7 07 18 00 **Traffic Coatings**

SONOGUARD®

Polyurethane waterproofing, traffic-bearing membrane systems for vehicular and pedestrian areas

Description

Sonoguard® waterproofing systems are composed of:

SONOGUARD® BASE COAT, a one-component, moisture-curing polyurethane,

SONOGUARD® TOP COAT, a one-component aliphatic moisture-curing polyurethane,

SONOGUARD® TOP COAT TINT BASE, consisting of 40 standard colors, (see Form No. 1017936).

For projects requiring primer, two choices are available:

PRIMER 772 VOC, a one-component solvent-based primer and sealer,

PRIMER 770, a two-component waterborne epoxy primer and sealer.

Yield

See chart on page 3.

Packaging

Primer 772 VOC:
5 gallon (18.93 L) pails

Primer 770:
4 gallon (15.14 L) units in 5 gallon pails (18.93 L)

Base Coat, (self-leveling and slope-grade):

5 gallon (18.93 L) pails
55 gallon (208 L) drums

Top Coat:
5 gallon (18.93 L) pails
55 gallon (208 L) drums

Features

- Meets EPA National requirements for VOC
- Primer coat not typically required
- Waterproof
- Excellent chloride resistance
- Seamless elastomeric membrane
- Skid resistant
- Multiple systems available
- Repairable and recoatable

Benefits

- Environmentally responsible
- Reduces labor and material costs
- Protects concrete from freeze/thaw damage; protects occupied areas below from water damage
- Protects from chloride intrusion; extends the life of reinforcing steel
- Offers excellent durability and superior abrasion resistance, has no seams that may result in leaks
- Increases safety
- Ideal for various vehicular or pedestrian traffic solutions
- Extends the useful life of the system

Top Coat Accelerator: 1 pint (473 mL) cans
Sonoguard® Adhesion Promoter (for recoat applications): 0.5 pint (236 mL) cans

Color

Standard colors: Gray, charcoal gray, and tan



Colors are approximate; conduct final color matching with actual material. For special colors, refer to Sonoguard® Top Coat Tint Base (Form No. 1017936).

Shelf Life

1 year when properly stored.

Storage

Store in unopened containers in a cool, clean, dry area.

Where to Use

APPLICATION

- Parking garages
- Stadiums
- Balconies
- Mechanical rooms
- Plaza decks

LOCATION

- Exterior or interior
- Above grade
- Suspended slabs

SUBSTRATE

- Elevated concrete slabs
- Exterior-grade plywood

Technical Data

Composition

Sonoguard® is a moisture-curing polyurethane membrane.

Compliances

- UL 790 Class A Fire Rating
- ASTM C 957
- ASTM E 108
- ASTM E 84

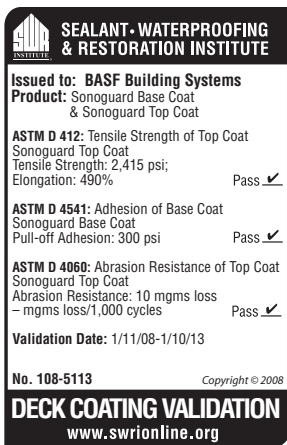

Test Data

PROPERTY*	RESULTS		TEST METHOD
	BASE COAT	TOP COAT	
Weight per gallon, lbs (kg)	9.9 (4.5)	9.1 (4.1)	ASTM D 1475
Specific gravity, kg/L	1.19	1.09	
Solids			ASTM D 1259
By weight, %	84	77	
By volume, %	81	75	
Viscosity, cps	4,000 – 9,000	2,000 – 4,000	ASTM D 2393
Flash Point, ° F (° C)	104 (40)	105 (40.5)	ASTM D 56

*Uncured material

PROPERTIES OF CURED MEMBRANES

PROPERTY	RESULTS		TEST METHOD/ REQUIREMENTS
	BASE COAT	TOP COAT	
Hardness, Shore A	60	89	ASTM D 2240
Tensile strength, psi (MPa)	752 (5.2)	2,500 (17.2)	ASTM D 412
Elongation, %	595	502	ASTM D 412
Tear strength, PIT	74	199	ASTM D 1004
Weight loss, %	16	17	Max: 40
Low temperature flexibility and crack bridging	No Cracking	No Cracking	No Cracking
Adhesion in peel after water immersion, pli,			
Primed mortar	43	N/A	5
Plywood	34	N/A	5
Adhesion (Pull-off), psi			
Base Coat	275		ASTM D 4541

CHEMICAL RESISTANCE TENSILE RETENTION (ASTM C 957)

CHEMICAL	RESULTS		REQUIREMENTS
	BASE COAT	TOP COAT	
Ethylene glycol	88	92	Min: 70
Mineral spirits	47	60	Min: 45
Water	96	83	Min: 70

Test results are averages obtained under laboratory conditions. Reasonable variations can be expected.

SONOGUARD® SYSTEM WEATHERING RESISTANCE AND ELONGATION RECOVERY (ASTM C 957)

PROPERTY	RESULTS		REQUIREMENTS
Elongation recovery, %	94		Min: 90
Tensile retention, %	151		Min: 80
Elongation retention, %	94		Min: 90
Abrasion resistance, mg lost; CS-17 Wheel, 1,000 g load, 1,000 cycles	1 — system passes	Max: 50	
Crack bridging, 1,000 cycles	System passes	—	

Test Data, cont.

	LIGHT TO MED TRAFFIC & PEDESTRIAN	HEAVY DUTY (REFUSAL METHOD)	EXTRA HEAVY DUTY (REFUSAL METHOD)
Base coat			
Wet mils (mm)	25 (0.6)	25 (0.6)	25 (0.6)
Dry mils (mm)	20 (0.5)	20 (0.5)	20 (0.5)
Coverage ¹	60 (1.5)	60 (1.5)	60 (1.5)
Mid coat			
Wet mils (mm)	None	20 (0.5)	25 (0.6)
Dry mils (mm)	None	15 (0.4)	20 (0.5)
Coverage ¹	None	80 (2.0)	60 (1.5)
Finish coat			
Wet mils (mm)	25 (0.6)	20 (0.5)	20 (0.5)
Dry mils (mm)	20 (0.5)	15 (0.4)	15 (0.4)
Coverage ¹	60 (1.5)	80 (2.0)	80 (2.0)
Aggregate²			
lbs per 100 ft ² (kg/m ²)	10 – 15 (0.5 – 0.7)	30 – 50 (1.5 – 2.5)	50 – 70 (2.5 – 3.4)

Coverage rates are approximate and may vary due to the application technique used. Actual coverage rate will also depend on finish and porosity of the substrate.

¹ Coverage is ft²/gal (m²/L)

² (16 – 30 mesh rounded silica sand or proportional equivalent)

How to Apply**Surface Preparation****CONCRETE**

- Concrete must be fully cured (28 days), structurally sound, clean, and dry (ASTM D 4263). All concrete surfaces (new and old) must be shotblasted to remove previous coatings, laitance, and all miscellaneous surface contamination and to provide profile for proper adhesion. Abrasive shotblasting must occur after concrete repair has taken place. Acid-etching is not permitted. Proper profile should be a minimum of ICRI CSP-3 (approximately 80 – 100 grit sandpaper).
- Repair voids and delaminated areas with BASF Construction Chemicals branded cementitious and epoxy patching materials. For application when fast-turn around repairs are required, Conipur® 265 can be used to repair patches up to 1" (25 mm) in depth. Please refer to Technical Service for proper application techniques.

SURFACE PRE-STRIPING AND DETAILING

- For nonmoving joints and cracks less than 1/16" (1.6 mm) wide, apply primer when required, followed by 25 wet mils (0.6 mm) prestriping of Base Coat. The Base Coat must be applied to fill and overlap the joint or crack 3" (76 mm) on each side. Feather the edges.

- Dynamic cracks and joints 1/16" (1.6 mm) and greater wide must be routed to a minimum of 1/4" by 1/4" (6 by 6 mm) and cleaned. Install bondbreaker tape to prevent adhesion of sealants to the bottom of joint. Prime joint faces only with Sonneborn® Primer 733 (see Form No. 1017962). Fill joints deeper than 1/4" (6 mm) with appropriate backer-rod and SL 1™/SL 2™ (slope grade or self-leveling) or NP 1™/NP 2™ sealants (see Form Nos. 1017903 and 1017911). For cracks, sealant should be flush with the adjacent concrete surface. For expansion joints, sealant should be slightly concave.
- Sealed joints 1" (25 mm) or less can be coated over with Sonoguard®. Expansion joints exceeding 1" (25 mm) wide should not be coated over with Sonoguard® so that they can perform independently of the deck coating system.
- Cut a 1/4" by 1/4" (6 by 6 mm) keyway into the concrete where the coating system will be terminated if no wall, joint, or other appropriate break exists. Fill according to instructions on cracks and joints over 1/16" (1.6 mm) wide.
- Form a sealant cant into the corner at the junction of all horizontal and vertical surfaces (wall sections, curbs, columns). Prime with Primer 733 and apply a 1/2 – 1" (13 – 25 mm) wide bead of NP 1™ or NP 2™ sealants. Tool to form a 45° cant.

- In locations of potential high movement, such as wall and slab intersections, apply 25 wet mils (0.6 mm) of Sonoguard® Base Coat and embed Sonoshield® Reinforcing Fabric.

METAL SURFACES

- Remove dust, debris, and any other contaminants from vent, drain-pipe, and post penetrations; reglets; and other metal surfaces.
- Clean these surfaces to bright metal and prime immediately with Primer 733.
- Provide appropriate cant with NP 1™, NP 2™, or Ultra sealant to eliminate 90° angles.

PLYWOOD

- All plywood must be smooth-faced, APA-stamped, and exterior grade. Construction must conform to code, but plywood must not be less than 15/32" (12 mm) thick. Plywood spacing and deck construction must follow APA guidelines.
- Surfaces must be free of contaminants. Priming is not necessary on clean, dry plywood.
- All seams must be caulked with NP 1™ or NP 2™ sealants (see Form Nos. 1017906 and 1017911). Prestripe 4 – 6" (102 – 152 mm) wide with 25 wet mils (0.6 mm) of Base Coat. Reinforce all seams between plywood sheets and between flashing and the plywood deck by embedding Sonoshield® Reinforcing Fabric into the prestriping.

APPLICATION OF PRIMER

Priming

NOTE: When primer is required on a job, follow these steps. When applying Sonoguard® without using a primer, proceed to Application.

1. After thoroughly vacuuming the surface, apply Primer 772 VOC or Primer 770 to all the properly prepared deck surfaces at the rate of 200 – 250 ft²/gallon (4.9 – 6.1 m²/L). Using a roller pan and a short- to medium-nap roller cover, force the primer into pores and voids to eliminate pinholes. Do not apply over prestripping. Use only solvent-resistant tools and equipment.

2. Allow primer to dry tack free. Base Coat must be applied the same working day.

Application of Base Coat

1. All preparatory work must be completed before application begins. Be certain the substrate is clean, dry, stable, and properly profiled. Sealants and prestripping should be properly cured. Apply the base, mid, and finish coats with a properly sized squeegee to arrive at the required mil thicknesses.

2. The best method to ensure the proper wet film thickness is the use of a grid system. Divide the surface to be coated into grids and calculate the square footage of each. Refer to the coverage chart to determine the quantity of Sonoguard® needed for each grid to arrive at the required mil thicknesses. For example, one pail of Sonoguard® Base Coat will cover an area approximately 300 ft² (28 m²), or a grid 30 by 10 ft (9 by 3 m) at 25 wet mils (0.6 mm). The mil thickness of all coats can also be verified by the use of a wet-mil thickness gauge.

3. Apply Base Coat 25 wet mils thick (0.6 mm) using a proper notched squeegee to entire deck surface, overcoating the properly prepared cracks, joints, and flashings. For sloped areas, use slope-grade Base Coat. Do not coat expansion joints over 1" (25 mm) wide.

4. Allow curing time of overnight (16 hour minimum). Slightly extend the curing time in cool or dry weather conditions. The surface of the base coat should have a slight tack. If the coating has been exposed for a prolonged period, consult Technical Service for recommendations.

Application Methods of Systems

Sonoguard® can be applied in several different systems depending on the degree of traffic the system is exposed to. In areas of extreme traffic (turning lanes, pay booths, ramps, entrances and exits), apply the Extra Heavy-Duty Traffic System (refusal method). The following summary briefly describes each method. All coverage rates are approximate.

IMPORTANT NOTE: All coverage rates are approximate and may vary due to the application technique used. Actual coverage rate will depend on finish and porosity of the substrate.

LIGHT- TO MEDIUM- DUTY TRAFFIC & PEDESTRIAN SYSTEM

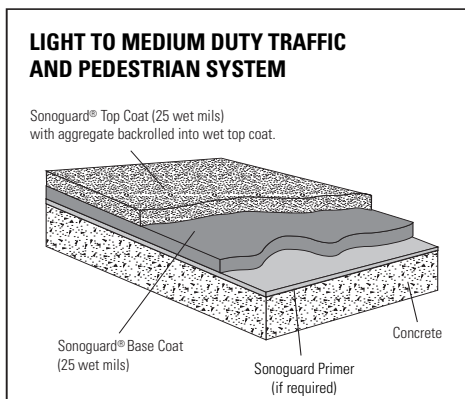

1. Prime concrete substrate (if required).
2. Apply 25 wet mils (0.6 mm) Sonoguard® Base Coat using a proper notched squeegee at 60 ft²/gallon (1.5 m²/L). Immediately backroll to level Base Coat. Allow to cure overnight.
3. Apply 25 wet mils (0.6 mm) Sonoguard® Top Coat using a proper notched squeegee at 60 ft²/gallon (1.5 m²/L). Immediately backroll to level Top Coat material. While the coating is still wet, broadcast Sonoguard® Aggregate or equivalent 16 – 30 rounded silica sand at 10 – 15 lbs/100 ft² (0.5 – 0.7 kg/m²), then backroll into the coating to fully encapsulate.

HEAVY-DUTY TRAFFIC SYSTEM

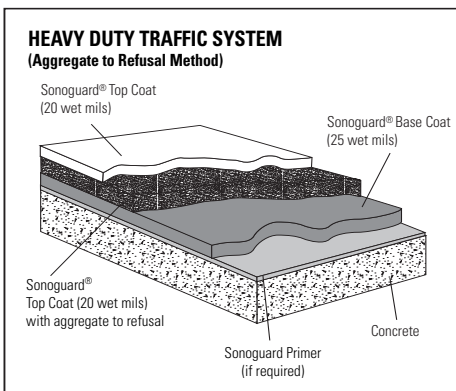

1. Prime concrete substrate (if required).
2. Apply 25 wet mils (0.6 mm) Sonoguard® Base Coat using a proper notched squeegee at 60 ft²/gallon (1.5 m²/L). Immediately backroll to level Base Coat. Allow to cure overnight.
3. Apply 20 wet mils (0.5 mm) Sonoguard® Top Coat using a notched squeegee at 80 ft²/gallon (2.0 m²/L). Immediately backroll to level Top Coat. While coating is still wet, broadcast Sonoguard® Aggregate or 16 – 30 rounded silica sand to refusal at approximately 30 – 50 lbs/100 ft² (1.5 – 2.4 kg/m²). Allow to cure overnight.
4. Remove all loose aggregate, then apply 20 mils (0.5 mm) Sonoguard® Top Coat using a flat squeegee at 80 ft² per gallon (2.0 m²/L). Immediately backroll to level Top Coat.
5. For additional slip resistance, immediately broadcast Sonoguard or equivalent 16-30 rounded silica sand at a rate of 7-10 lbs/100 ft² (.34-.49 kg/m²) and backroll to encapsulate.

EXTRA HEAVY-DUTY SYSTEM

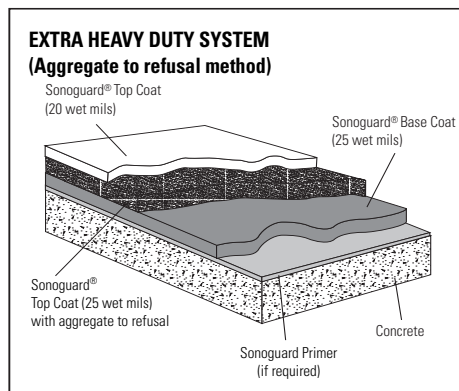

1. Prime concrete substrate (if required).
2. Apply 25 wet mils (0.6 mm) Sonoguard® Base Coat using a proper notched squeegee at 60 ft²/gallon (1.5 m²/L). Immediately backroll to level Base Coat. Allow to cure overnight.
3. Apply 25 wet mils (0.6 mm) Sonoguard® Top Coat using a proper notched squeegee at 50 ft²/gallon (1.2 m²/L). Immediately backroll to level Top Coat. While the coating is still wet broadcast Sonoguard® Aggregate or 16 – 30 rounded silica sand to refusal at 50 – 70 lbs/100 ft² (2.5 - 3.4 kg/m²). Allow to cure overnight.
4. Remove all loose aggregate, then apply 20 mils (0.5 mm) Sonoguard® Top Coat using a flat squeegee at 80 ft²/gallon (2.0 m²/L). Immediately backroll to evenly level Top Coat.
5. For additional slip resistance, immediately broadcast Sonoguard aggregate or equivalent at a rate of 7-10 lbs/ft² (.34-.49 kg/m²) and backroll to encapsulate.

Mockup

Provide mockup of at least 100 ft² (9.3 m²) to include surface profile, sealant joint, crack, flashing, and juncture details and allow for evaluation of slip resistance and appearance of Sonoguard® Systems.

1. Install mockup with specified coating types and with other components noted.
2. Locate where directed by architect.
3. Mockup may remain as part of work if acceptable to architect.

For recoat applications, see Sonoguard® Recoat System product data sheet.

Curing Time

Allow curing time of 72 hours before vehicular use and 48 hours before pedestrian use. Extend the curing time in cool-weather conditions. To reduce the timeframe in which Sonoguard® might be vulnerable to inclement weather or to reduce the time between coats, use Sonoguard® Top Coat Accelerator.

Maintenance

1. Portions of the membrane that exhibit wear are considered a maintenance item, and are not considered a warrantable item.
2. Surfaces may be cleaned with commercial detergents. Sonneborn recommends that a maintenance agreement be established between the owner and applicator.
3. Periodic inspection and repair of damaged surfaces will greatly prolong the performance and life of the system.
4. Remove all sharp debris, such as sand, gravel, and metal on a regular basis to avoid damage to the coating.
5. When removing snow, avoid the use of metal blades or buckets that may damage the coating.

Clean Up

Clean all tools and equipment with Reducer 990 or xylene.

For Best Performance

- Concrete should have a minimum compressive strength of 3,000 psi (20.7 MPa) and be cured for a minimum of 28 days.
- For slab on grade applications please contact BASF representative.
- Be sure to allow for movement in the deck by the proper design and use of expansion and control joints.
- When applying sealants, use backing materials according to industry standards.
- Do not apply when substrates are over 110° F (32° C) or under 40° F (4° C).
- When used interior, provide adequate ventilation with a minimum of 6 air changes per hour.
- When adequate ventilation for use of Sonoguard® cannot be maintained, refer to product data sheet for Conipur II Deck Coating System (Form No. 1017917).
- Be certain that all aggregate not properly encapsulated is thoroughly removed.
- On steep ramps in excess of 15%, contact your local BASF representative.
- Sonoguard® Aggregate 16/30, rounded select silica sand is recommended.
- When applying to metal pan decks or decks containing between-slab membranes, contact Technical Service.
- Select the proper amount of aggregate to promote slip resistance.
- Prestripe to level out recessed sealant joints (less than 1" [25 mm]) for optimal aesthetic appearance.
- Avoid application of Sonoguard® when inclement weather is present or imminent.
- Do not apply Sonoguard® to damp, wet, or contaminated surfaces.
- Sonoguard® is not suitable for use where chained or metal-studded tires will be used.
- Make certain the most current versions of product data sheet and MSDS are being used; call Customer Service (1-800-433-9517) to verify the most current versions.
- Proper application is the responsibility of the user. Field visits by BASF personnel are for the purpose of making technical recommendations only and not for supervising or providing quality control on the jobsite.

Troubleshooting

Problem—likely causes:

Irregular appearance—substrate too rough, uneven coating application, uneven aggregate distribution. SOLUTION: Recoating may improve appearance. The number of additional coat(s) is dependent on the degree of irregularity. A sample recoat should be done.

Premature wear over high spots—failure to grind down abnormally rough concrete or junctions of slabs that do not line up evenly. SOLUTION: Grind high areas. Recoat affected area with entire Sonoguard® system.

Uneven aggregate distribution—casting aggregate into an uneven coating, not casting aggregate consistently. SOLUTION: Aggregate should be evenly distributed before encapsulation. If the surface cures unevenly, a recoat may improve appearance. Use a sample area to gauge results of recoat.

Inadequate slip resistance—inconsistent coating application, failure to properly embed aggregate, overly heavy finish coat. SOLUTION NO. 1: When installing aggregate to refusal method, incorporate an additional 10 lb/100 ft² (0.5 kg/m²) aggregate into the final lock coat. SOLUTION NO. 2: Start with a sample area. Lightly abrade surface to expose aggregate. Refer to Sonoguard® Recoat product data sheet.

Blisters—coating application too heavy or a wet substrate. SOLUTION: Cut blisters and spot repair as needed.

Poor adhesion to concrete—concrete surface too smooth (not properly profiled) or friable; concrete contaminated by dirt, oil, or moisture, etc. SOLUTION: Fix underlying problem, then reapply Sonoguard® system.

Intercoat adhesion is poor—preceding coat contaminated by dirt or moisture; topcoat applied past critical recoat time. SOLUTION: Fix underlying problem, then reapply Sonoguard® system. For additional information, contact Sonneborn® Technical Service.

Sagging in vertical applications—SOLUTION: Apply multiple thin coats of both base and top coats to achieve desired film thickness. If puddling does occur, backroll as soon as possible.

Health and Safety

SONOGUARD® BASE COAT

Warning

Sonoguard® Base Coat contains titanium dioxide, talc, calcium carbonate, calcium sulfate, stoddard solvent, toluene diisocyanate, and silicon dioxide.

Risks

Combustible liquid and vapor. Inhalation of vapors may cause irritation and intoxication with headaches, dizziness and nausea. May cause skin and eye irritation. Potential skin and/or respiratory sensitizer. Ingestion may cause irritation. Reports associate repeated or prolonged occupational overexposure to solvents with permanent brain, nervous system, liver and kidney damage. INTENTIONAL MISUSE BY DELIBERATELY INHALING THE CONTENTS MAY BE HARMFUL OR FATAL.

Precautions

KEEP OUT OF THE REACH OF CHILDREN. KEEP AWAY FROM HEAT, FLAME AND SOURCES OF IGNITION. Avoid contact with skin, eyes or clothing. Wash thoroughly after handling. DO NOT take internally. Use only with adequate ventilation. Use impervious gloves, eye protection and if the TLV is exceeded or used in a poorly ventilated area, use NIOSH/MSHA approved respiratory protection in accordance with applicable federal, state and local regulations. Keep container closed. All label warnings must be observed until container is commercially cleaned or reconditioned.

First Aid

In case of eye contact, flush thoroughly with water for at least 15 minutes. SEEK IMMEDIATE MEDICAL ATTENTION. In case of skin contact, wash affected areas with soap and water. If irritation persists, SEEK MEDICAL ATTENTION. Remove and wash contaminated clothing. If inhalation causes discomfort, remove to fresh air. If discomfort persists or any breathing difficulty occurs, or if swallowed, SEEK IMMEDIATE MEDICAL ATTENTION.

Refer to Material Safety Data Sheet (MSDS) for further information.

Proposition 65

This product contains materials which are known to the state of California as known to cause cancer, birth defects, or other reproductive harm.

VOC Content

Self-leveling grade: 1.63 lbs/gal or 196 g/L of VOC, less water and exempt solvents.

Flash/slope grade: 1.7 lbs/gal or 203.3 g/L of VOC, less water and exempt solvents.

SONOGUARD® TOP COAT

Warning

Sonoguard® Top Coat contains mineral spirits, talc, calcium sulfate, and methylene bis (4-cyclohexylisocyanate); it may also contain titanium dioxide and silicon dioxide.

Risks

Combustible liquid and vapor. May cause skin and eye irritation. May cause dermatitis and allergic responses. Potential skin and/or respiratory sensitizer. Inhalation of vapors may cause irritation and intoxication with headaches, dizziness and nausea. Ingestion may cause irritation. Reports associate repeated or prolonged occupational overexposure to solvents with permanent brain, nervous system, liver and kidney damage. INTENTIONAL MISUSE BY DELIBERATELY INHALING THE CONTENTS MAY BE HARMFUL OR FATAL.

Precautions

KEEP OUT OF THE REACH OF CHILDREN. KEEP AWAY FROM HEAT, FLAME AND SOURCES OF IGNITION. Keep container closed when not in use. Use only with adequate ventilation. Avoid contact with skin, eyes and clothing. Wash thoroughly after handling. Avoid breathing vapors. Use impervious gloves, eye protection and if the TLV is exceeded or if used in a poorly ventilated area, use NIOSH/MSHA approved respiratory protection in accordance with applicable federal, state and local regulations. Empty container may contain explosive vapors or hazardous residues. Do not cut or weld on or near empty container. All label warnings must be observed until container is commercially cleaned or reconditioned.

First Aid

In case of eye contact, flush thoroughly with water for at least 15 minutes. SEEK IMMEDIATE MEDICAL ATTENTION. In case of skin contact, wash affected areas with soap and water. If irritation persists, SEEK MEDICAL ATTENTION. Remove and wash contaminated clothing. If inhalation causes discomfort, remove to fresh air. If discomfort persists or any breathing difficulty occurs, or if swallowed, SEEK IMMEDIATE MEDICAL ATTENTION.

Refer to Material Safety Data Sheet (MSDS) for further information.

Proposition 65

This product contains material listed by the state of California as known to cause cancer, birth defects, or other reproductive harm.

VOC Content

1.75 lbs/gal or 209 g/L of VOC, less water and exempt solvents.

**For medical emergencies only,
call ChemTrec (1-800-424-9300)**

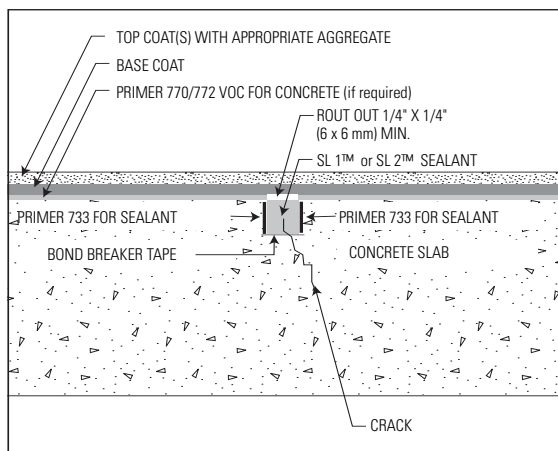

Crack Detail (Dynamic)

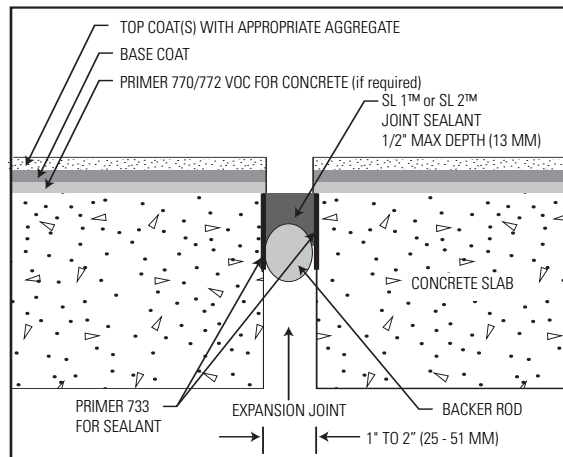

Expansion Joint Detail (Greater Than 1")

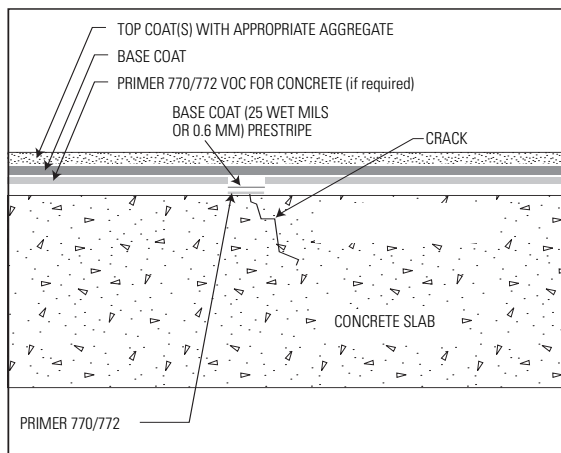

Crack Detail (Static)—Sporadic Cracking

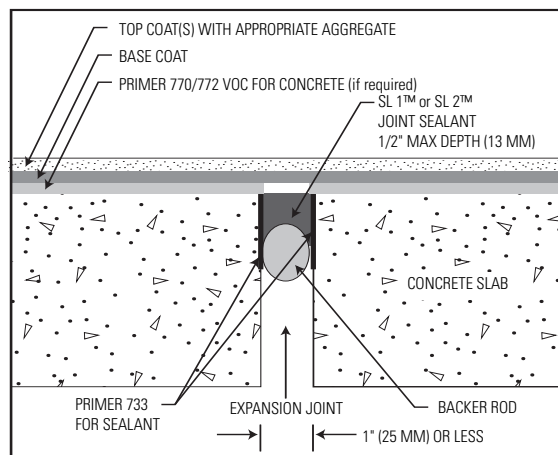

Expansion Joint Detail (Less Than 1")

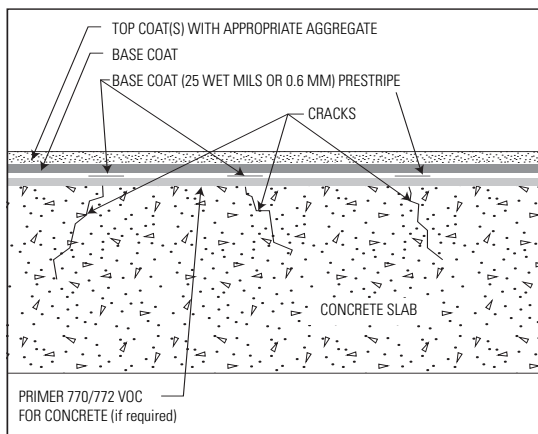

Crack Detail (Static)—Alternate Option for Widespread Cracking

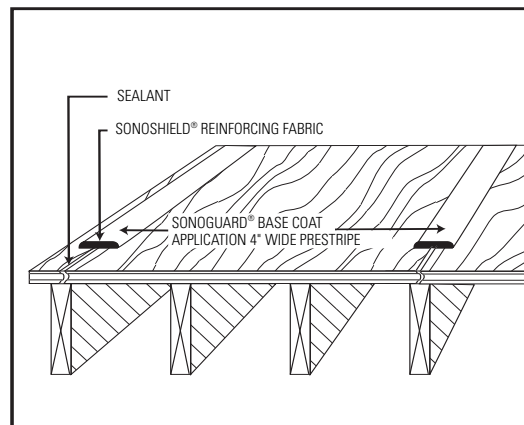

Plywood Application (Seam Detail)

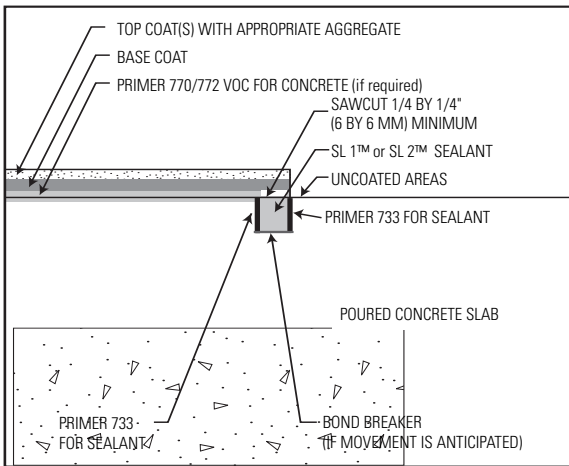

Key-way or Termination Detail

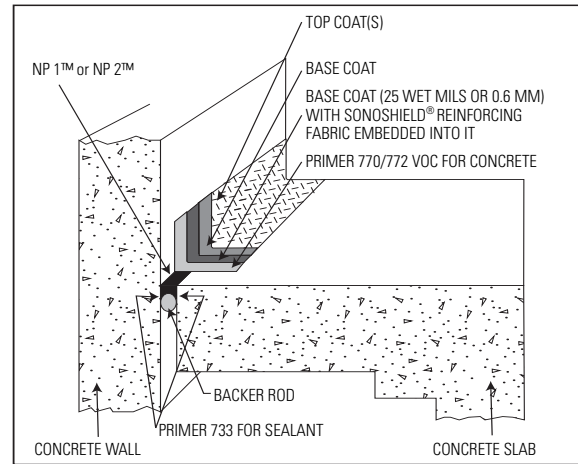

Joint at Wall/Slab

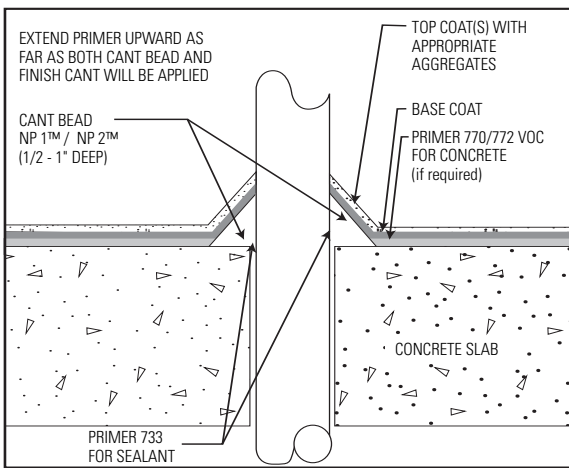

Penetration Detail

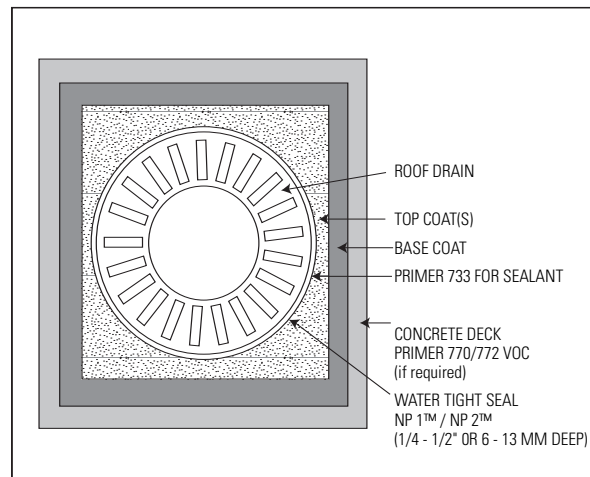

Roof Drain

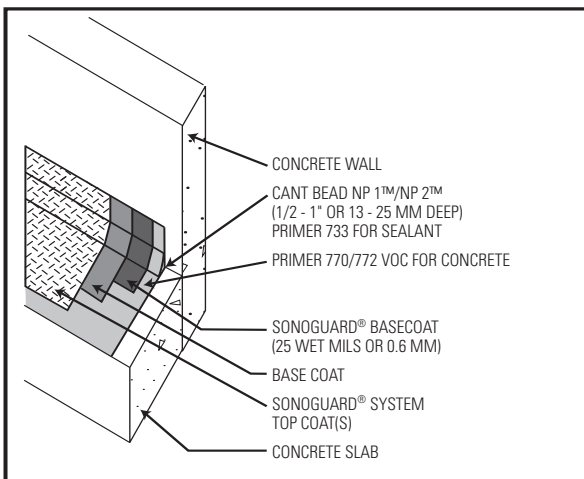

Slab Abutting Wall

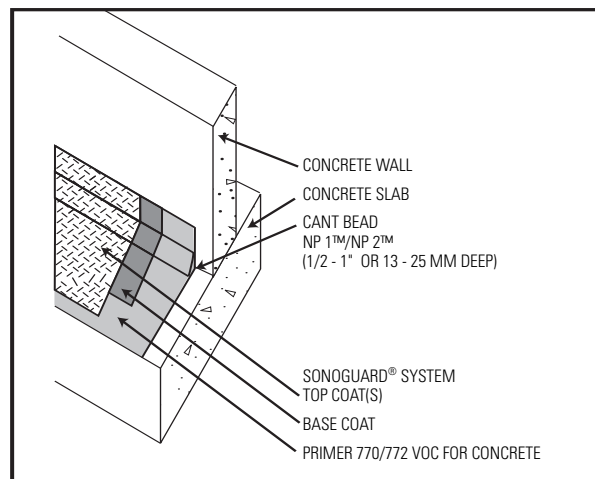

Wall Bearing on Slab

BASF Construction Chemicals, LLC – Building Systems

889 Valley Park Drive
Shakopee, MN, 55379

www.BuildingSystems.BASF.com

Customer Service 800-433-9517
Technical Service 800-243-6739



LIMITED WARRANTY NOTICE Every reasonable effort is made to apply BASF exacting standards both in the manufacture of our products and in the information which we issue concerning these products and their use. We warrant our products to be of good quality and will replace or, at our election, refund the purchase price of any products proved defective. Satisfactory results depend not only upon quality products, but also upon many factors beyond our control. Therefore, except for such replacement or refund, BASF MAKES NO WARRANTY OR GUARANTEE, EXPRESS OR IMPLIED, INCLUDING WARRANTIES OF FITNESS FOR A PARTICULAR PURPOSE OR MERCHANTABILITY, RESPECTING ITS PRODUCTS, and BASF shall have no other liability with respect thereto. Any claim regarding product defect must be received in writing within one (1) year from the date of shipment. No claim will be considered without such written notice or after the specified time interval. User shall determine the suitability of the products for the intended use and assume all risks and liability in connection therewith. Any authorized change in the printed recommendations concerning the use of our products must bear the signature of the BASF Technical Manager.

This information and all further technical advice are based on BASF's present knowledge and experience. However, BASF assumes no liability for providing such information and advice including the extent to which such information and advice may relate to existing third party intellectual property rights, especially patent rights. In particular, BASF disclaims all CONDITIONS AND WARRANTIES, WHETHER EXPRESS OR IMPLIED, INCLUDING THE IMPLIED WARRANTIES OF FITNESS FOR A PARTICULAR PURPOSE OR MERCHANTABILITY. BASF SHALL NOT BE RESPONSIBLE FOR CONSEQUENTIAL, INDIRECT OR INCIDENTAL DAMAGES (INCLUDING LOSS OF PROFITS) OF ANY KIND. BASF reserves the right to make any changes according to technological progress or further developments. It is the customer's responsibility and obligation to carefully inspect and test any incoming goods. Performance of the product(s) described herein should be verified by testing and carried out only by qualified experts. It is the sole responsibility of the customer to carry out and arrange for any such testing. Reference to trade names used by other companies is neither a recommendation, nor an endorsement of any product and does not imply that similar products could not be used.

For professional use only. Not for sale to or use by the general public.